

RIGEL
Total Power. Total Trust.

Introduction to IEC 60601 And IEC 62353 Clarity or Confusion?

Oslo, Norway
12th March 2008

By John Backes
In association with AkuMED

RIGEL
Total Power. Total Trust.

Format

- § Introduction
- § Markets
- § IEC 60601
- § IEC 62353
- § Considerations
- § Recommendations

RIGEL
Total Power. Total Trust.

Rigel Medical

- § Seaward Group (UK) including Clare Instruments, Cropico and Seaward Electronic.
- § Offices in UK and Florida
- § Specialised in the design, development and manufacturing of electrical test equipment.
- § First IEC 601 Electrical Safety Analyser in the 1970's

RIGEL
Total Power. Total Trust.

Rigel Medical



Rigel 8001
Rigel 233



RIGEL
Total Power. Total Trust.

Electrical current

- § Closed circuit (ie Live to Earth)
- § Source of Energy
- § Stimulate cells (nerves and muscles)
- § Excess can cause burns in tissue
- § Involuntary Muscle Contraction (Tetanus)
- § Paralyse Respiratory system (heart / lungs)
- § Cause of Ventricular Fibrillation
- § Life saver – Defibrillation – reset heart
- § AC / DC have different effects

RIGEL
Total Power. Total Trust.

| | |
|-------|--------------------------------|
| 6A | Heart defibrillation |
| 1A | Severe Burns |
| | Heart clamps - no fibrillation |
| 200mA | Severe Risk of Macroshock |
| 100mA | Ventricular Fibrillation |
| | Breathing problems |
| | Muscular paralysis |
| 10mA | Let go threshold |
| | Mild sensation |
| 1mA | Perception of shock |
| | Severe Risk of MicroShock |
| | Ventricular Fibrillation |
| 100uA | |
| 10uA | Risk of Microshock |
| 0uA | Safe |

Howard M. Hochberg, 1971

Importance?



- § Current of 10uA (too small to perceived), can have serious affects on the cardiac rhythm.
- § Patients can be weakened, connected to ME Equipment for a period of time and even anaesthetised.
- § Famous quote:
"If something can go wrong, it will go wrong"

Market sectors



- § Hospitals (public & private)
- § Medical Manufacturers (R&D & Manufacturing)
- § Contract Service (3rd Party & Manufacturers)
- § MOD (Field Hospitals)
- § Education
- § Test Authorities

Testing Needs

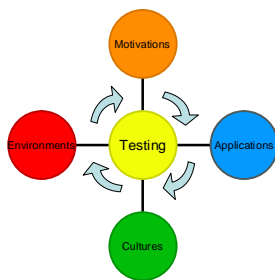

IEC 60601-1



- § Design and Type-Test standard (Mandatory)
- § Electrical and Mechanical Safety and Compliance of **Medical Electronic Equipment**
- § Ensure Safety of Patient / User and Environment

ME Definition



- § Treatment, Monitoring or Diagnoses of patients,
- § Single mains connection
- § Physical or electrical contact
- § Transfers energy to or from the patient or
- § Detects such energy transfer to or from the patient.



ME Class



- ⊕ § ME class 1 (Protection relying on fault currents to Earth)
- § ME class 2 (Double Insulated, protection relying on additional insulation)

ME Type



 § Type B - Earth Referenced
 § Type BF – Non Cardiac. Patient Circuit Floating type.
 § Type CF – Cardiac. Patient Circuit Floating type.

Variants



§ BS / EN 60601
 § AAMI / ES 60601
 § UL 2601
 § AS / NZ 3200
 § CSA C22.2

Body Model



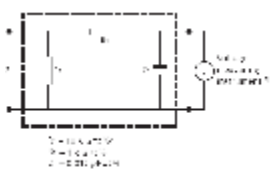
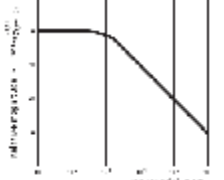



Patient Environment

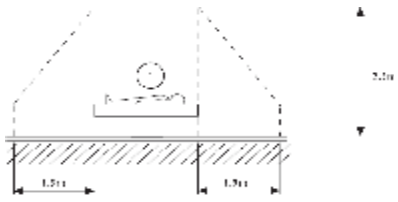



Patient Environment



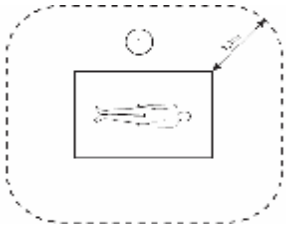

IEC 60601-1 Tests



§ Earthbond Bond Test
 § HIPOT Test (Creepage / Clearance)
 § Leakage Tests (SFC's)

- Earth
- Enclosure / Touch
- Patient (AC / DC)
- Patient Auxiliary (AC / DC)
- Patient type F

 § SIP / SOP SFC

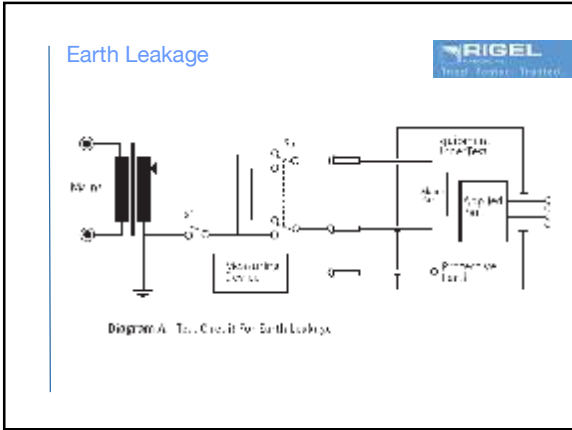

Earth Leakage

§ Applicable to B / BF / CF (Class 1 only)

§ Conditions

1. Normal Supply
2. Normal Supply, Open Neutral
3. Reversed Supply
4. Reversed Supply, Open Neutral

§ Limits 0.5mA / 1mA (SFC) 2nd edition

§ Limits 5mA / 10mA (SFC) 3rd edition

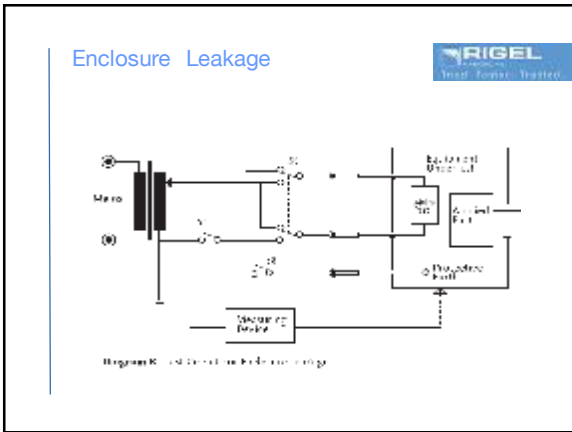

Enclosure leakage

§ Applicable to B / BF / CF

§ Conditions

1. Normal Supply
2. Normal Supply, Open Neutral
3. Normal Supply, Open Earth (Class 1 only)
4. Reversed Supply
5. Reversed Supply, Open Neutral
6. Reversed Supply, Open Earth (Class 1 only)

§ Limits 0.1mA / 0.5mA (SFC)

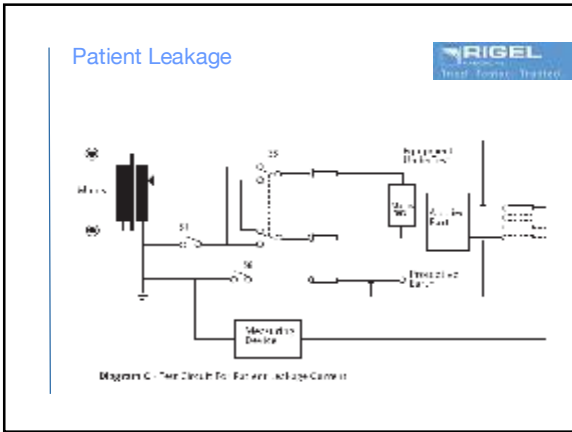

Patient Leakage

§ Applicable to B / BF / CF

§ Conditions

1. Normal Supply
2. Normal Supply, Open Neutral
3. Normal Supply, Open Earth (Class 1 only)
4. Reversed Supply
5. Reversed Supply, Open Neutral
6. Reversed Supply, Open Earth (Class 1 only)

§ AC and DC reading

Patient Leakage



- § Patient Connections shorted within Applied Part for B and BF
- § Patient Connections measured separately within Applied Part for CF
- § Limits B / BF (AC) 0.1mA / 0.5mA (SFC)
- § Limits CF (AC) 0.01mA / 0.05mA (SFC)
- § Limits B/BF/CF (DC) 0.01mA / 0.05mA (SFC)

Patient AUX Leakage

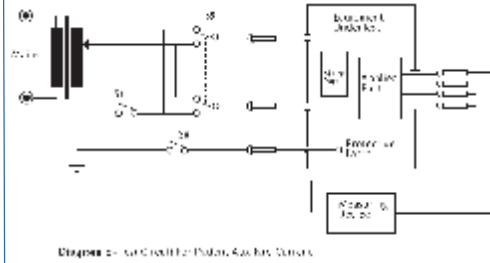

Patient Aux leakage



- § Applicable to B / BF / CF
- § Conditions
 1. Normal Supply
 2. Normal Supply, Open Neutral
 3. Normal Supply, Open Earth (Class 1 only)
 4. Reversed Supply
 5. Reversed Supply, Open Neutral
 6. Reversed Supply, Open Earth (Class 1 only)
- § AC and DC reading

Patient Aux Leakage



- § Each Patient Connections to all other Connections shorted within Applied Part
- § Limits B / BF (AC) 0.1mA / 0.5mA (SFC)
- § Limits CF (AC) 0.01mA / 0.05mA (SFC)
- § Limits B/BF/CF (DC) 0.01mA / 0.05mA (SFC)

Patient F-type Leakage

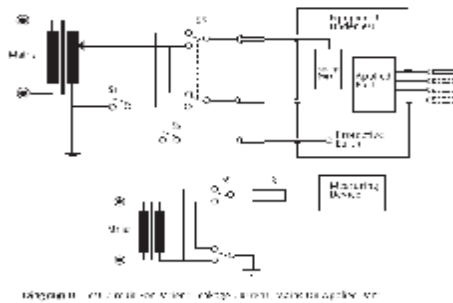

Patient F-Type leakage



- § Applicable to BF & CF only
- § Current Limited to 5mA max at 110% of mains
- § Conditions
 1. Normal Supply, Source Normal
 2. Normal Supply, Source Reversed
 3. Reversed Supply, Source Normal
 4. Reversed Supply, Source Reversed
- § RMS reading

Patient F-Type Leakage



- § Patient Connections shorted within Applied Part for BF
- § Patient Connections measured separately within Applied Part for CF
- § Limits BF (AC) 5mA
- § Limits CF (AC) 0.05mA

Example of Class 1, 10CF



| | | |
|---------------------------|----------------------------------|---------|
| § No of measurements; | | |
| 1. | Earth Leakage | 4 |
| 2. | Enclosure Leakage | 6 |
| 3. | Patient Leakage (6 x 10 x 2) | 120 |
| 4. | Patient Aux Leakage (6 x 10 x 2) | 120 |
| 5. | Patient Type F Leakage(4 x 10) | 40 ± |
| § Total (excl. earthbond) | | 290 !!! |

Example of Class 1, 5BF



| | | |
|---------------------------|---------------------------------|--------|
| § No of measurements; | | |
| 1. | Earth Leakage | 4 |
| 2. | Enclosure Leakage | 6 |
| 3. | Patient Leakage (6 x 1 x 2) | 12 |
| 4. | Patient Aux Leakage (6 x 5 x 2) | 60 |
| 5. | Patient Type F Leakage(4 x 1) | 4 ± |
| § Total (excl. earthbond) | | 86 !!! |

Example of Class 1, 5CF+ 2BF



| | | |
|---------------------------|-----------------------------------|---------|
| § No of measurements; | | |
| 1. | Earth Leakage | 4 |
| 2. | Enclosure Leakage | 6 |
| 3. | Patient Leakage (CF) (6 x 5 x 2) | 60 |
| 4. | Patient Leakage (BF) (6 x 1 x 2) | 12 |
| 5. | Patient Aux Leakage (6 x 7 x 2) | 84 |
| 6. | Patient Type F Leakage(CF)(4 x 5) | 20 |
| 7. | Patient Type F Leakage(BF)(4 x 1) | 4 ± |
| § Total (excl. earthbond) | | 190 !!! |

Example of Class 2, 10CF



| | | |
|-----------------------|----------------------------------|---------|
| § No of measurements; | | |
| 1. | Enclosure Leakage | 4 |
| 2. | Patient Leakage (4 x 10 x 2) | 80 |
| 3. | Patient Aux Leakage (4 x 10 x 2) | 80 |
| 4. | Patient Type F Leakage(4 x 10) | 40 ± |
| § Total | | 204 !!! |

Example of Class 2, 5BF



| | | |
|-----------------------|---------------------------------|--------|
| § No of measurements; | | |
| 1. | Enclosure Leakage | 4 |
| 2. | Patient Leakage (4 x 1 x 2) | 8 |
| 3. | Patient Aux Leakage (4 x 5 x 2) | 40 |
| 4. | Patient Type F Leakage (4 x 1) | 4 ± |
| § Total | | 56 !!! |

What do we most
associate with
IEC 60601-1?



Entering IEC 62353

IEC 62353

- § Recurrent Test and Test After Repair
- § Guideline
- § Electrical Safety
- § Visual Inspection, Bonding, Leakage, Insulation
- § Risk Assessment
- § Record keeping
- § Functional Testing

IEC 62353

- § Not Mandatory
- § Not a replacement of IEC 60601-1-1
- § Not a replacement of Local Standard
- § Does not describe Mechanical Safety or
- § Electro Magnetic Compatibility

Parallel to IEC 62353

- § VDE 0751 (Mandatory)
- § AS / NZ 3551 (Mandatory)
- § HEI95 / MDA DB 9801/2006 (Guidelines)
- § IPPEM (Guidelines)
- § NFPA-99 (Type-Test)
- § ES / EN / IEC 60601-1 (Type-Test)

Best practice



- § Experience
- § Recommendations
- § Risk assessment
- § Manufacturers recommendations
- § Reduced IEC 60601-1
- § AC / DC or just AC
- § 1A, 10A, 25A
- § Mains on Applied Parts destructive or not

Visual Inspection



- § Housing – Enclosure
- § Contamination
- § Cabling (supply, Applied Parts etc)
- § Fuse rating
- § Markings and Labelling
- § Integrity of mechanical parts

Bonding



- § Minimum 200mA AC / DC into 500m Ω
- § Reversed Polarity for DC
- § Maximum 24 V o.c. voltage
- § 300m Ω

Considerations



- § High Test Currents (10A or more)
- § Low Test Currents (<8A)
- § Contact Resistance

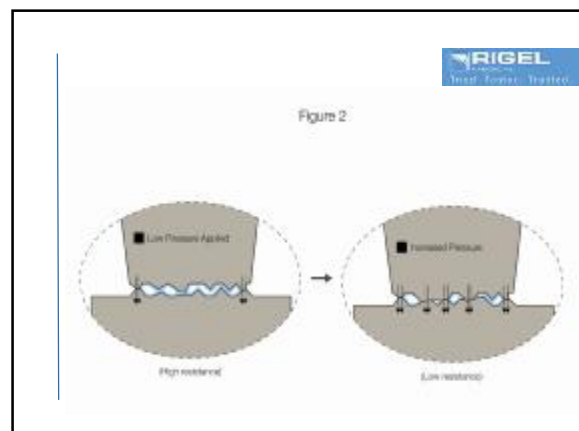
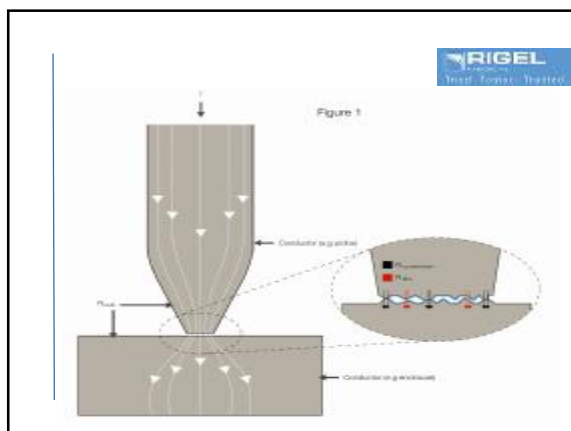

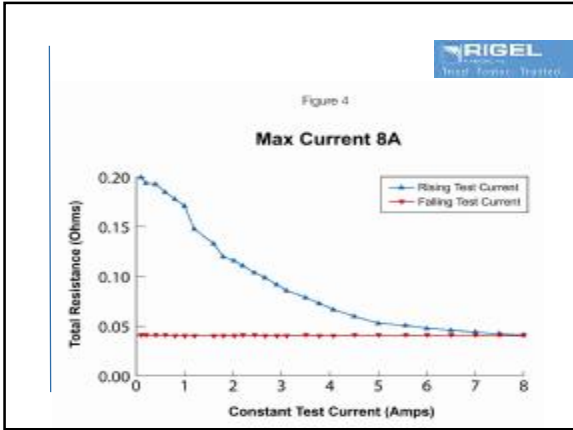
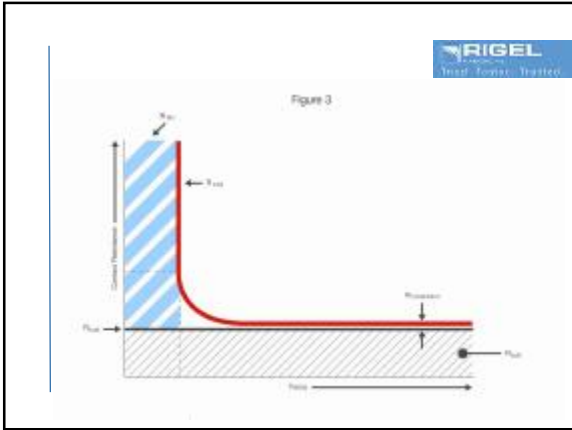

- Insulation**
- § Optional Test
 - § Equipment Breakdown
 - § Mains Parts to Earth / Ground
 - § Applied Parts to Earth / Ground
 - § Applied Parts to Mains (F-type only)
 - § 500VDC

- Leakage**
- § Equipment Leakage
 - § Applied Part Leakage
 - § Different Methods
 - § Common Patient Connections
 - § Total Leakage
 - § Compare

- Equipment Leakage**
- § Total leakage deriving from the AP's, Enclosure and Mains Parts combined to real Earth.
 - § Class I and II.
 - § B, BF and CF equipment.
 - § All Patient Connections / AP's shortened
 - § RMS value.

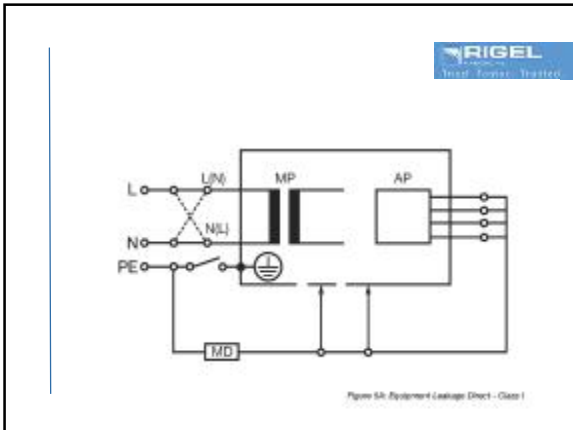

Considerations

- § Direct Method
- § Differential Method
- § Alternative Method
- § Repeat Failed Tests (individual AP's)
- § Repeat Failed Tests (individual PC's)
- § Compare results (Trends)



Applied Part Leakage

- § Total leakage of Patient Connections (AP) to Earth, (non) conductive parts on the enclosure.
- § Fault condition Mains on Applied Parts.
- § 3.5mA limited @ mains frequency.
- § Floating type (BF & CF), Class I and II.
- § Group Patient Connections of single function.
- § Excluded AP's left floating
- § RMS value

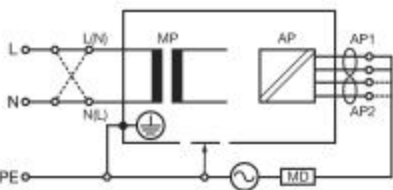

Figure 53. Applied Part Leakage Direct - Class II

Example of Class 1, 10CF

- § No of measurements;

| | |
|-----------------------------------|---|
| 1. Equipment Leakage (Dir / Diff) | 2 |
| 2. Applied Part Leakage (Dir) | 2 |
| § Total (excl. earthbond) | 4 |
- (vs 290 in IEC 60601!!!)



Example of Class 1, 5CF +2BF

- § No of measurements;

| | |
|-----------------------------------|---|
| 1. Equipment Leakage (Dir / Diff) | 2 |
| 2. Applied Part Leakage (Dir) | 4 |
| § Total (excl. earthbond) | 6 |
- (vs 190 in IEC 60601!!!)



Example of Class 1 or 2, 1B

- § No of measurements;

| | |
|-----------------------------------|---|
| 1. Equipment Leakage (Dir / Diff) | 2 |
| § Total (excl. earthbond) | 2 |



Considerations

- § Direct Method
- § Alternative Method
- § Touchable Mains Voltage
- § Repeat Failed Tests (individual PC's)
- § Compare results (Trends)



IEC 60601 F-Type

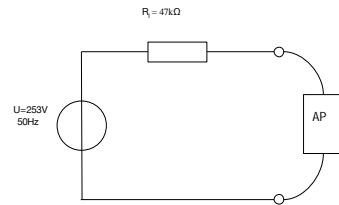

IEC 60601 F-Type

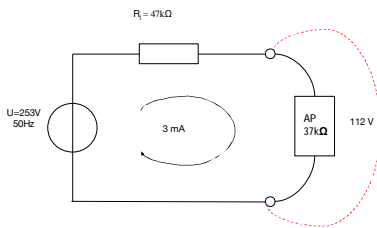

IEC 62353 Applied Part Leakage

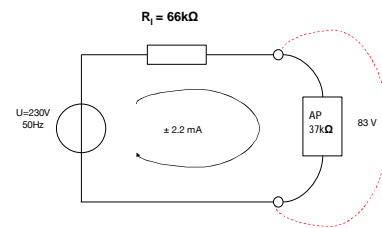

IEC 62353 mains compensation

$$(230V / 83V) \times 2.2 \text{ mA} = 6 \text{ mA}$$



60601 vs 62353

Type BF limit = 5mA

Result (60601) 3 mA (PASS)

Result (62353) 6 mA (FAIL)



Methods

- § Direct Method
- § Differential Method
- § Alternative Method



Direct Method

- § True Leakage to Earth through MD
- § Direct comparison IEC 60601-1.
- § AC and DC leakage current.
- § Highest accuracy



Direct Method

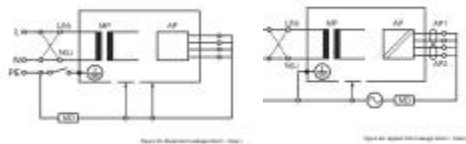

Considerations

- § Ground Interrupted
- § The 1kΩ resistor (MD)
- § Secondary Earth path
- § Polarity of the Live and Neutral
- § TN (Terre – Neutral) system

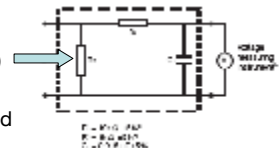

Differential Method

- § I_{Δ} Phase – Neutral.
- § Total equipment leakage current.
- § Impartial to Secondary Earth connections.
- § Protective Ground Intact. (no 1KΩ)
- § Safer working practice.



Considerations

- § Relatively in-accurate (<100μA).
- § External magnetic fields.
- § High current consumption of the DUT.
- § Limited frequency response <20Hz
- § Polarity Phase – Neutral
- § AC only



Differential method

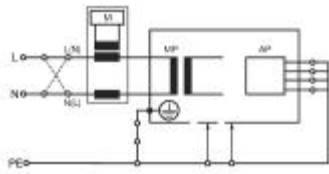

Figure 16 Equipment Leakage (Differential) – IEC 60601

Alternative method

- § Similar to a Dielectric Strength Test
- § Current Limited Mains potential / frequency.
- § Polarity not applicable (P-N short)
- § TN-System not applicable
- § Secondary Earth not applicable
- § Battery powered instrument.
- § Highly repeatable
- § Breakdown of dielectrics

Considerations

- § Current limiting resistor.
- § Measuring voltage is dependent on the test load.
- § Measured leakage current is scaled
- § Equipment is not be activated
- § Not directly comparable with IEC 60601.

Alternative method

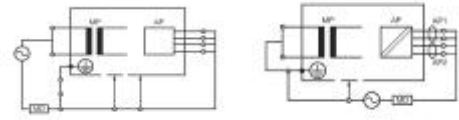

Figure 17 Equipment Leakage (Series) – IEC 60601

Figure 18 Equipment Leakage (Shunt) – IEC 60601

Record Keeping

- § Paper based or Electronic?
- § Structured
- § Protocols
- § Comparing data
- § Trends
- § Scheduling
- § Traceability
- § Peace of Mind

Summary & Considerations

- § Which IEC 62353 methods meet my requirement's
- § Are my Test Instruments compatible?
- § Install Base or New Equipment only?
- § Updating and Communicate Service Procedures / Manuals
- § Is further Training Required?
- § Record Keeping

What can 62353 do for me?



- § Geared-up to meet future trends
- § Follow manufacture's recommended tests
- § Save Time & Money,
- § Increase effectiveness
- § Advocates safe working practise
- § Increases flexibility

What Can Rigel Offer You?



- § Rigel 288 - Hand-Held ESA
- § IEC 60601-1 & IEC 62353
- § 1.7Kg
- § 10 Patient Connections
- § Full / Semi Automatic
- § New Earthbond Technologies.
- § BlueTooth Communication



Rigel 288



- § Customer Test Sequences
- § Battery Power
- § PC Up and Download Software
- § Bar code scanning
- § Result printing
- § Barcode pass fail printing

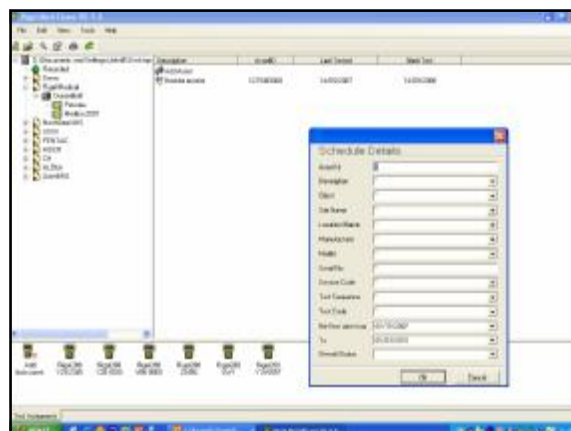
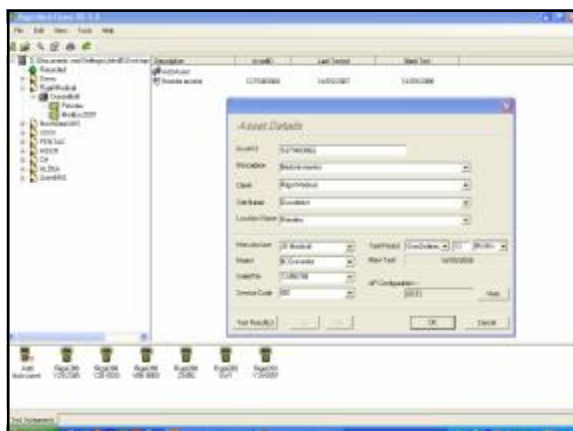

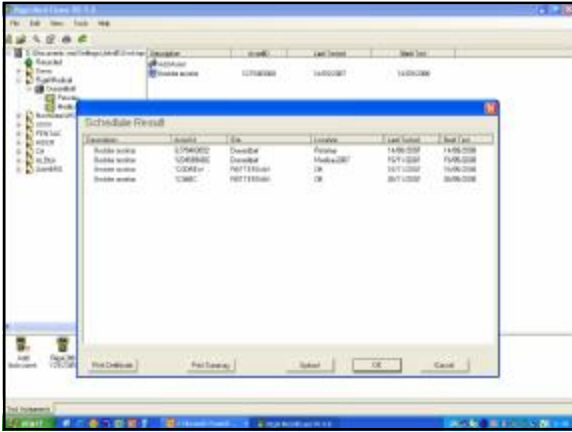



Thank you for your interest

- § Any Questions?
- § Free Booklets Available
- § Demo Rigel 288

